

# Volumetric Compensation of machine tools with SIEMENS Sinumerik 840D

Don't be satisfied with less!

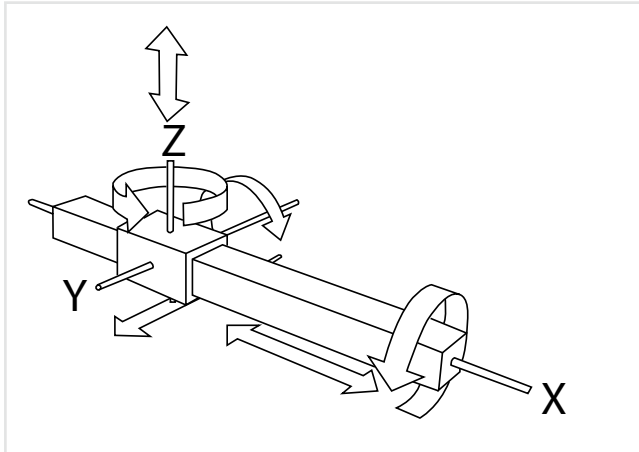

## Customers

Our customers are machine tool builders, CNC control producers, retrofit companies as well as users incorporation machine tooling in their production line.

## State-of-the-art

The accuracy of parts, being produced is governed by the accuracy of the cartesian axes (X, Y, Z) of the machine tool.

The conventional methods used to establish machine tool deviations result in lengthy down time and therefore high costs. In most cases an additionally mechanical correction of the machine tool axes is necessary to resolve any deviations.

## Innovation

With LaserTRACER Systems we are measuring the volumetric deviation in the whole workspace of the machine tool. The evaluation will be given as a protocol with diagrams for each of the systematic deviations. Positioning, straightness, squareness, yaw pitch and roll errors will be completely measured.

The software-option VCS (Volumetric Compensation System) from company SIEMENS allows a process correction file created by AfM to be entered directly into the Sinumerik 840D and from there it can be worked on online.

This results in a noticeable improvement of the volumetric accuracy in the entire workspace of the machine tool. Hereby the complicated mechanical correction of the machine tool can often be avoided.

The possible increase of volumetric accuracy is more than 50%!

## Your Advantages

- Faster error mapping reduces down time and therefore costs.
- An increase of volumetric accuracy of more than 50% through VCS Compensation in the 840D control unit.
- Usually no mechanical correction is necessary, also after collisions.
- Higher machine availability by Condition Monitoring

# Volumetric Compensation of machine tools

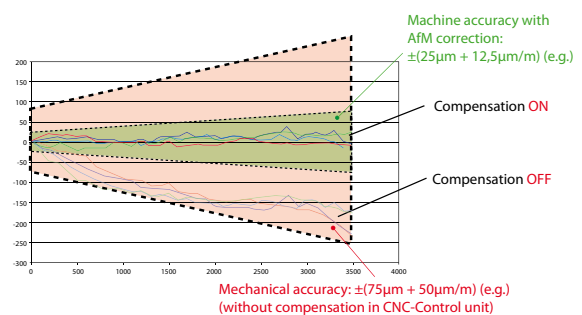

## Use of the most up-to-date laser technology

- Automated self-tracking laser interferometer with temperature stable construction.
- Highest accuracy through patented reference sphere.
- No complicated fine alignment on the machine tool.
- 4 – 6 measuring positions in the workspace of the machine tool for the evaluation of the complete volumetric deviation are required.
- Total time: approx. 4-6 hours
- Resolution:  $0,001 \mu\text{m}$
- Accuracy:  $0,2 \mu\text{m} + 0,3 \mu\text{m/m}$
- Range:  $0,2 \text{ m} - 15 \text{ m}$   
(extendable by mathematical superposition)
- Principle: Multilateration

## Our Services

- Fast, cost-effective volumetric machine tool analysis
- Documentation of actual conditions
- Creation of compensation files
- Verification of the compensated machine tool
- Standard machine calibrations
- Mechanical service and adjustment
- Training for LaserTRACER systems
- Sale of LaserTRACER systems and accessories

Solution Partner

Automation

SIEMENS

**AfM**  
Accuracy for Machines

**AfM Technology GmbH**  
Gartenstraße 133  
73430 Aalen  
Germany

Fon +49(0) 73 61 88 96 08-0  
Fax +49(0) 73 61 88 96 08-99

info@afm-tec.de  
www.afm-tec.de