

Volumetric Compensation of machine tools with FANUC control unit

Don't be satisfied with less!

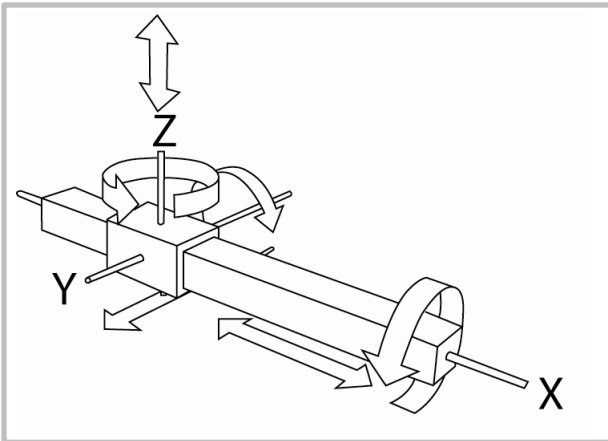

Customers

Our customers are machine tool builders, CNC control producers, retrofit companies as well as users incorporating machine tooling in their production line.

State-of-the-art

The accuracy of parts being produced is governed by the accuracy of the cartesian axes (X, Y, Z) of the machine tool.

The conventional methods used to establish machine tool deviations result in lengthy down time and therefore high costs. In most cases an additionally mechanical correction of the machine tool axes is necessary to resolve any deviations.

Innovation

With LaserTRACER Systems we are measuring the volumetric deviation in the whole workspace of the machine tool. The evaluation will be given as a protocol with diagrams for each of the systematic deviations. Positioning, straightness, squareness, yaw pitch and roll errors will be completely measured.

The software-options **MaCo Online** (AfM) and **3D Compensation** (FANUC) allow a process correction file created by AfM to be entered directly into the **FANUC** control unit and from there it can be worked on online.

This results in a noticeable improvement of the volumetric accuracy in the entire workspace of the machine tool. The possible increase of volumetric accuracy is mostly of more than 50%.

Your advantages

- Fast error mapping reduces down time and therefore costs
- An increase of volumetric accuracy of more than 50% through
 - **AfM MaCo Online (0i-D, 16i, 18i, 21i, 30i, 31i, 32i)**
Volumetric Compensation including tool vector
 - **FANUC 3D Compensation (30i, 31i, 32i)**
Space Error Compensation
- Usually no mechanical correction is necessary
- Higher machine availability by Condition Monitoring

Volumetric Compensation of machine tools

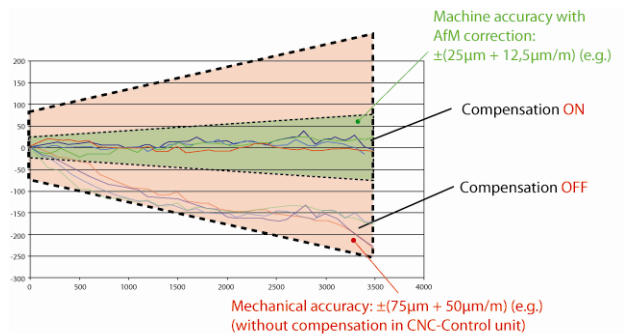

Use of the most up-to-date laser technology

- Automated self-tracking laser interferometer with temperature stable construction.
- Highest accuracy through patented reference sphere.
- No complicated fine alignment on the machine tool.
- 4 – 6 measuring positions in the workspace of the machine tool for the evaluation of the complete volumetric deviation are required.
- Total time: approx. 4 - 6 hours
- Resolution: 0,001 μm
- Accuracy: 0,2 μm + 0,3 $\mu\text{m}/\text{m}$
- Range: 0,2 m – 15 m
(extendable by mathematical superposition)
- Principle: Multilateration

Our Services

- Fast, cost-effective, volumetric machine tool analysis
- Documentation of actual conditions
- Creation of Compensation files
- Verification of the compensated machine tool
- Standard machine calibrations
- Mechanical service and adjustment
- Training for LaserTRACER systems
- Sale of LaserTRACER systems and accessories

AfM
Accuracy for Machines

AfM Technology GmbH
Gartenstraße 133
73430 Aalen
Germany

Fon +49 (0) 73 61 88 96 08-0
Fax +49 (0) 73 61 88 96 08-99
www.afm-tec.de
info@afm-tec.de